

# SINGLE DRAWER MODULE



## ASSEMBLY INSTRUCTIONS

**READ THESE INSTRUCTIONS BEFORE STARTING ANY ASSEMBLY.**



**DANGER: THE BENCH TOP IS FACTORY ASSEMBLED AND READY TO USE, DO NOT ATTEMPT ANY MODIFICATION (eg. CUTTING, DRILLING OR SANDING). MODIFICATION WILL CREATE CRYSTALLINE SILICA DUST. REFER TO THE SUPPLIED SAFETY DATA SHEET FOR MORE DETAILS. MODIFICATIONS SHOULD ONLY BE MADE BY EXPERIENCED TRADESPERSONS UNDER CONTROLLED CONDITIONS.**

**WARNING! – THIS IS A PERMANENT CONNECTION SYSTEM!**

## WHAT'S NEEDED?

### Tools Required:

- Nylon mallet (Not Included)
- Philips head screwdriver or drill (Not included)
- Allen Keys x 2 (included in blister pack)

### THIS MODULE IS PACKED IN THREE BOXES: BOX 1 OF 3 = BENCH TOP

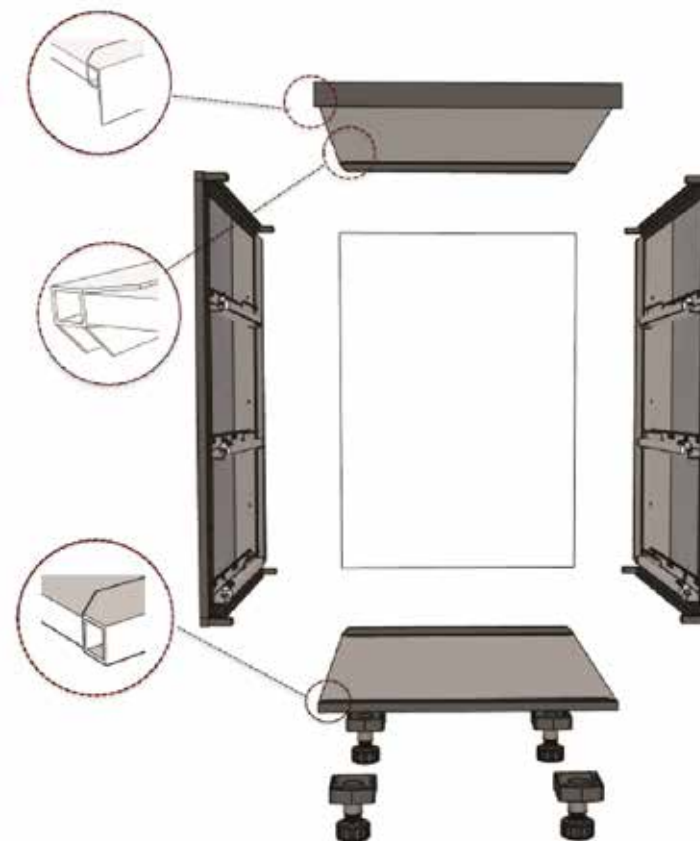
- SINTERED STONE BENCH TOP

### BOX 2 OF 3 = DRAWER MODULE PANELS & FRAMES

- PVC & THERMAL PANELS AND FRAMES
- HARDWARE BLISTER PACK
- PLINTH FEET

### BOX 3 OF 3 = DRAWER FRONTS

## LAYOUT DIAGRAM



**FIG. 1**

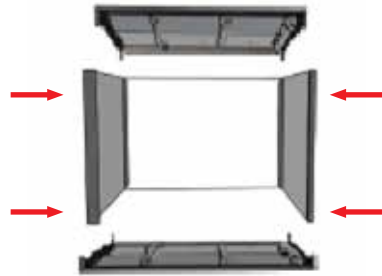
**Essential Tip:** Ensure you have a stable, flat surface to knock your modules together on; ideally concrete.

Please take the time look at our instruction manual to familiarise yourself with the product before starting.

## ASSEMBLING BACK PANEL

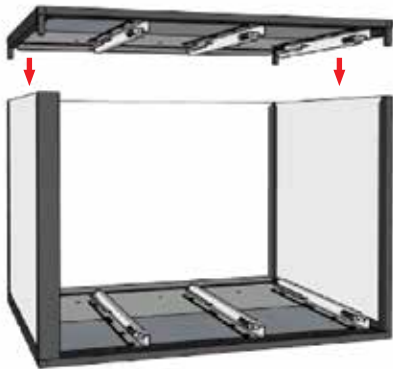


**FIG. 2**



**FIG. 3** Position the left side panel on the ground so that it is easier to assemble.

## ASSEMBLING SIDE WALL PANELS TO BACK PANEL

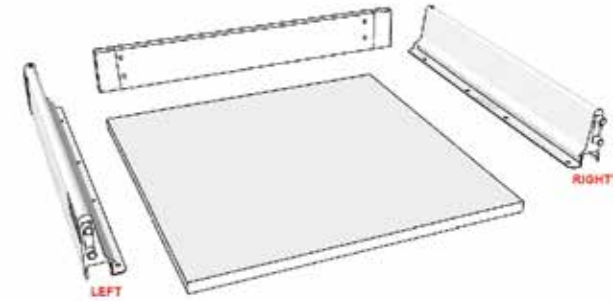


**FIG. 4**

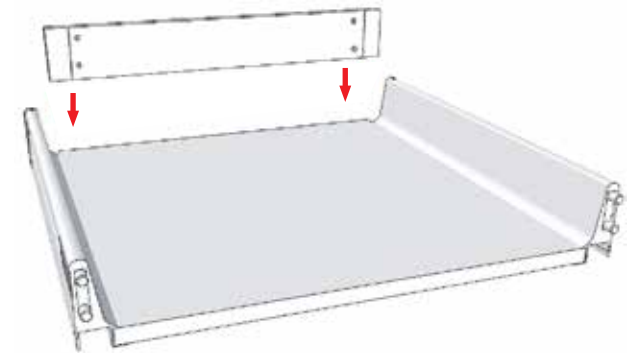


**FIG. 5** Now turn module 90 degrees onto its base

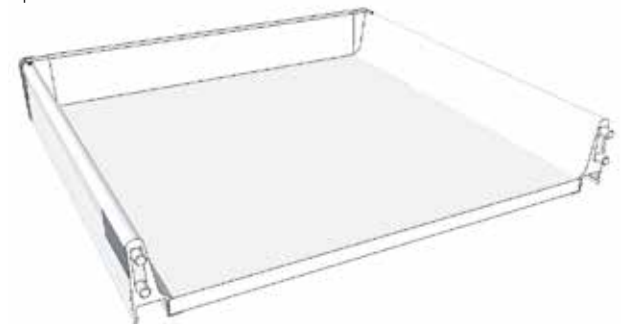
## ASSEMBLING DRAWER



**FIG. 6** Using the screws (4 per side) provided assembled the left and the right side to the base plate.



**FIG. 7** The rear panel is pre-assembled push down into the left and the right sides and push all the way down to the base plate.



**FIG. 8** Finished drawer kit should look like this.  
**Note:** Repeat the 3 steps shown in FIG. 6 through FIG. 8 for the remaining 2 drawers

## ATTACHING THE ADJUSTABLE PLINTH FEET

No pilot holes are used for plinth feet since the inside frame edge provides the guide. Place Plinth foot into corner of cabinet frame.

Using a **HAND SCREW DRIVER** only gently screw in each of the screws.

Do NOT use a battery screw driver, only a hand screw driver.

Failing to use a hand screw driver may cause the screw to go too far through the PVC and damage the inner surface of the base.

If desired move the front two plinth feet further back to create a deeper kick plate position.



FIG. 9

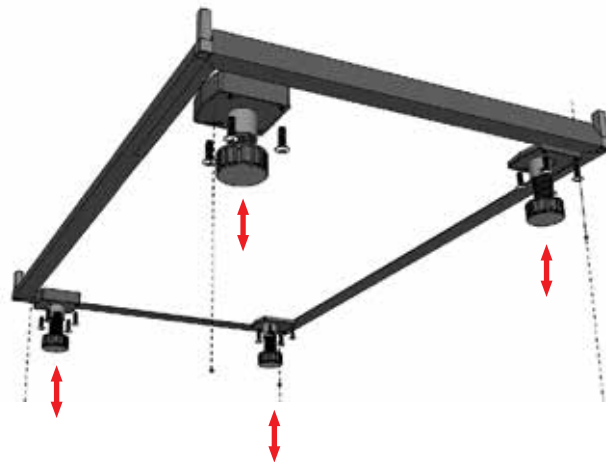


FIG. 10

## ATTACHING THE KICK PLATE

Please take note that the kick plate provided is reversible, thereby giving you the choice between a black "shadow line" finish or stylish silver finish. The kick plate biscuit is used to connect onto more than one cabinet, thereby aligning the kick plate.

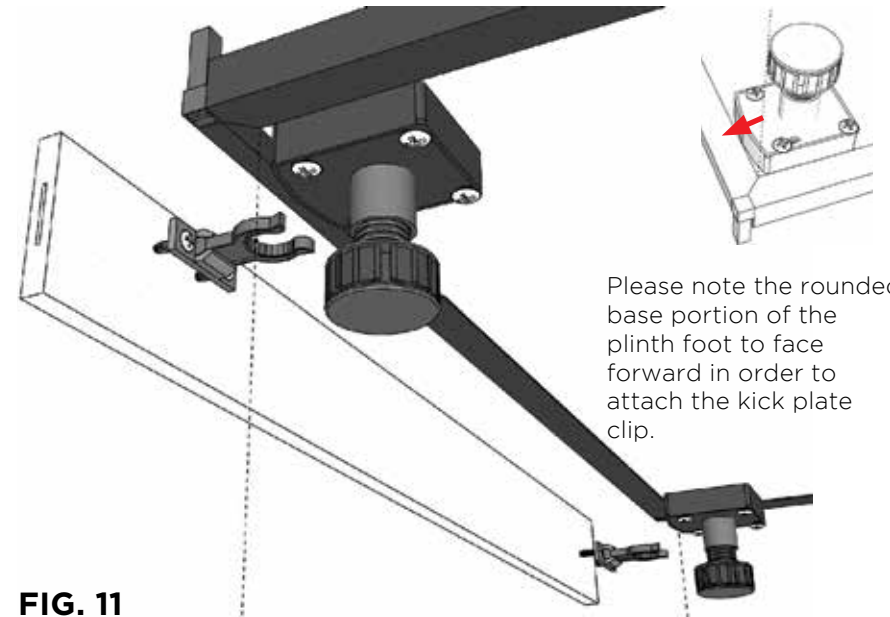


FIG. 11

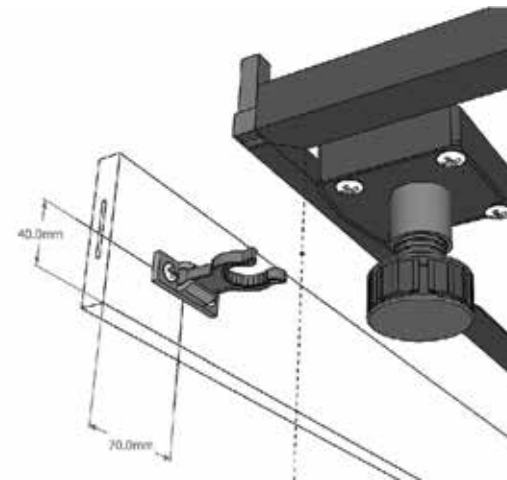


FIG. 12

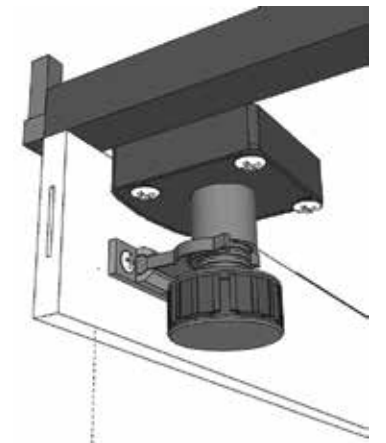
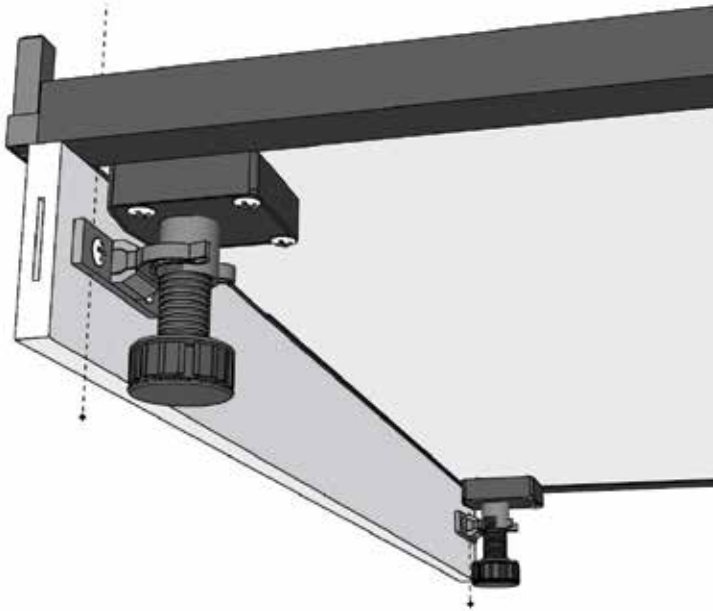


FIG. 13

Choose the desired color face of kick plate (Silver or Black).

No pre-drilled holes are possible due to this color choice.

Self tapping screws are provided to attach the spring clip plate to the kick panel. The dimensions on FIG. 11 can be used as a guide only since the position of the plinth foot and the desired depth of the kick plate will vary depending on the choice of plinth foot installation position by the end user.

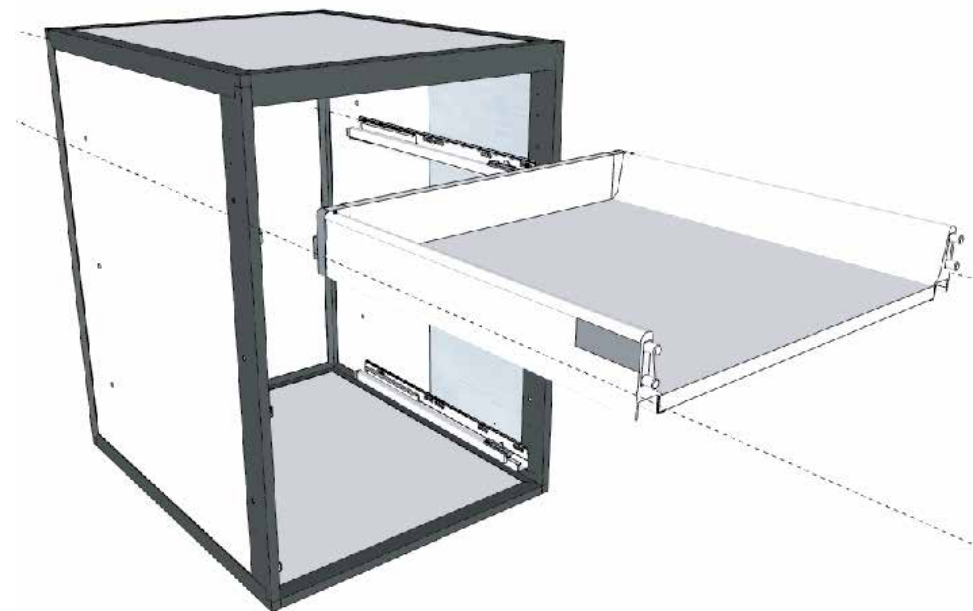


**FIG. 14**

## **FINISHING DRAWERS**

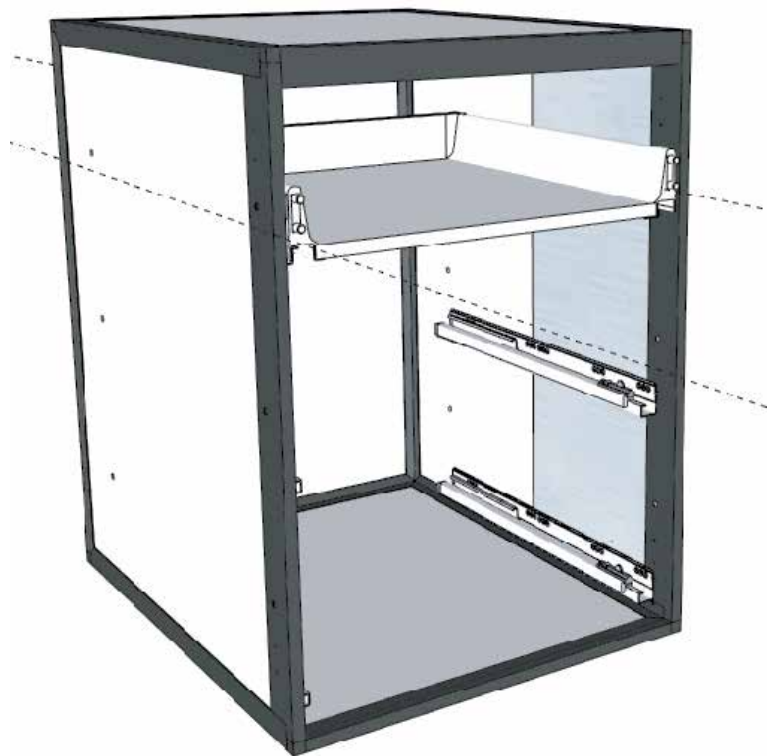
**NOTE:** Please fit the cabinet joining screws **BEFORE** starting the finishing of the drawers. If you forget you will need to remove the drawers again to access the joining holes, refer page 16 for how to remove drawers.

Slide out the drawer runner from each cabinet side and position the drawer onto the two runners.



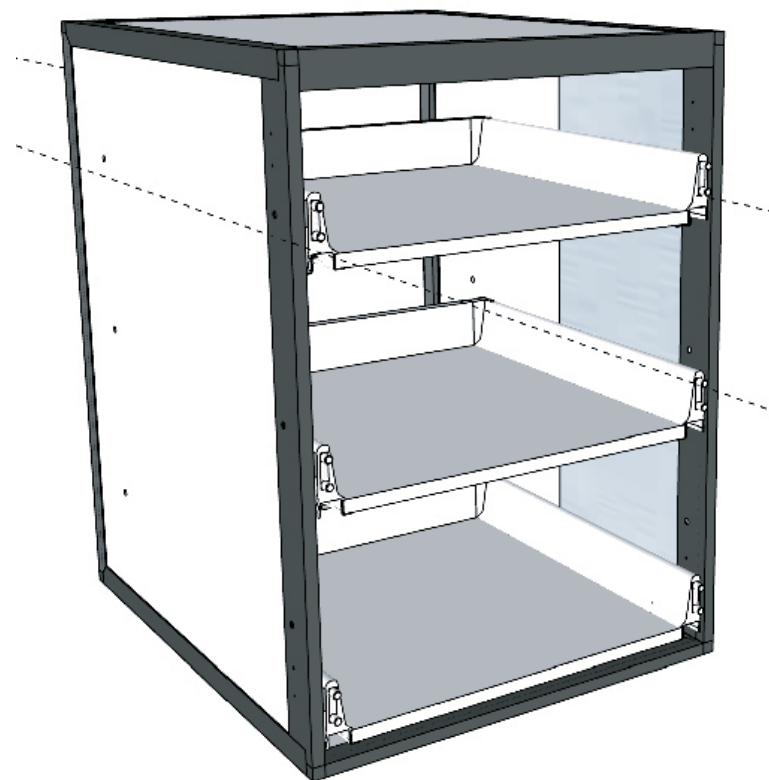
**FIG. 15**

With runners and drawer positioned gently push the drawer into the cabinet, the runners will “click” into place.



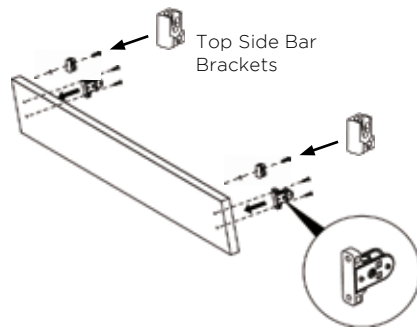
**FIG. 16**

Repeat the above steps, FIG. 15 and FIG. 16 for the remaining two drawers.



**FIG. 17**

## INSTALL DRAWER FRONTS



**FIG. 18** Fit the drawer front brackets and top side bar brackets using the screws provided.

Note: The top side bar brackets are fitted the top side bars, slide the square cover back to reveal bracket, unclip then screw into place.

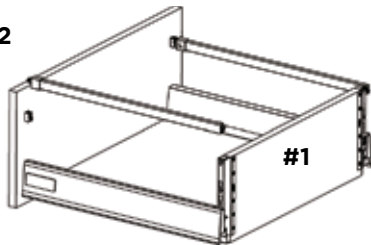
It may also be best to attached the handle at this stage, refer page 13.

Draw Front Brackets



**FIG. 19** To fit the drawer front to the drawer base, pull the base forward and place your palm in drawer base to hold push and click the drawer front into position.

#2



**FIG. 20** Keep the drawer open. Fit, push down and click the rear of the top side bars into position.

Slide the square cover backwards and clip into place in the top side bracket. Slide the square cover forwards to cover and hold in place.



**FIG. 21** Push completed drawer into the cabinet and repeat FIG. 18 through FIG. 21 for the remaining two drawers.

## INSTALL DRAWER HANDLES



**FIG. 22**



**FIG. 23**

Remove the Double sided Tape from the inside of the handle. Ensure you align the holes of the handle with the pre-drilled holes in the drawer front before touching the tape to the drawer front panel. Carefully press the door handle to the drawer front for a permanent adhesion.



**FIG. 24**



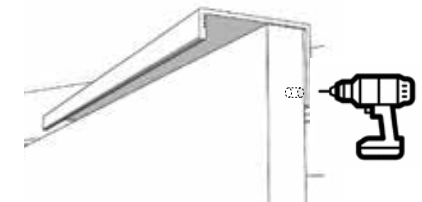
**FIG. 25**

Additional screws are provided for a very secure connection, using a hand screw driver screw the screws through the handle holes and into the predrilled holes in the drawer front. These additional screw fixtures are not required under normal use.

### IMPORTANT

- **3.2mm drill bit with a depth stop (not supplied)**
- Please ensure you use a stop or tape on the drill bit, so not to drill deeper than 9mm maximum into the door. Damage to the door from incorrect drilling will not be covered under warranty.

Use tape to set the depth to 9mm max.



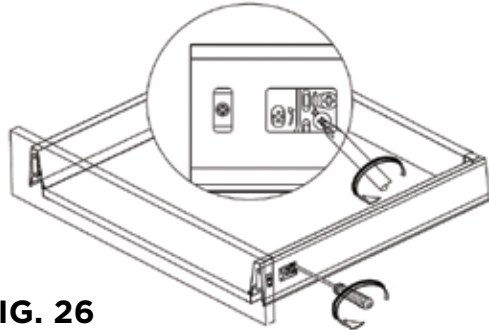
## ADJUSTING THE DRAWER FRONT

Once the drawer module is level the drawer fronts may need to be adjusted up/down or left/right to ensure a consistent look. The maximum adjustment is +/- 2mm.

### Adjusting Up/Down

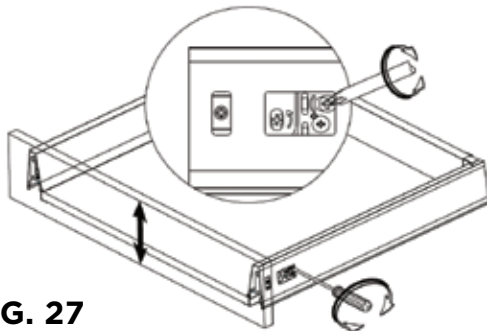
The adjustment is on the front outer side of each drawer side, triple screw opening.

1. Unlock the screw.



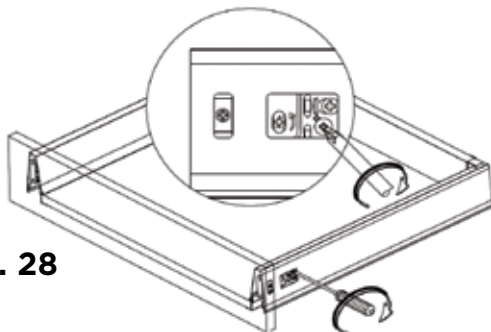
**FIG. 26**

2. Rotate the screw clockwise for up and anti-clockwise for down.



**FIG. 27**

3. Once happy with the position lock the screw.

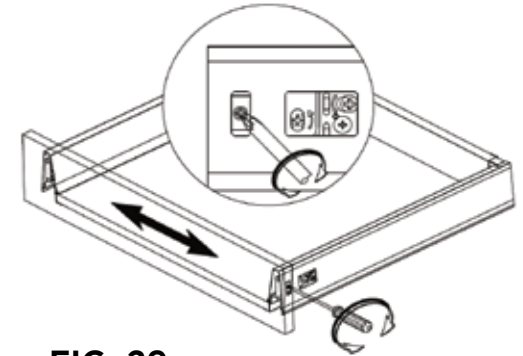


**FIG. 28**

### Adjusting Left/Right

The adjustment is on the front outer side of each drawer side, single screw opening.

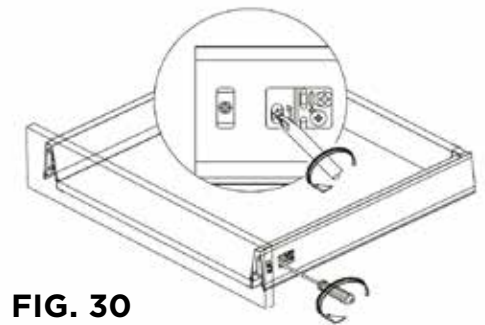
4. Rotate the screw clockwise for right and anti-clockwise for left.



**FIG. 29**

## REMOVE DRAWER FRONT

1. Slide the square cover back on both of the top side bars.
2. Unclip both of the top side bars from the drawer front.



**FIG. 30**

NOTE: These 2 top side bars MUST BE unclipped from the drawer front before proceeding.

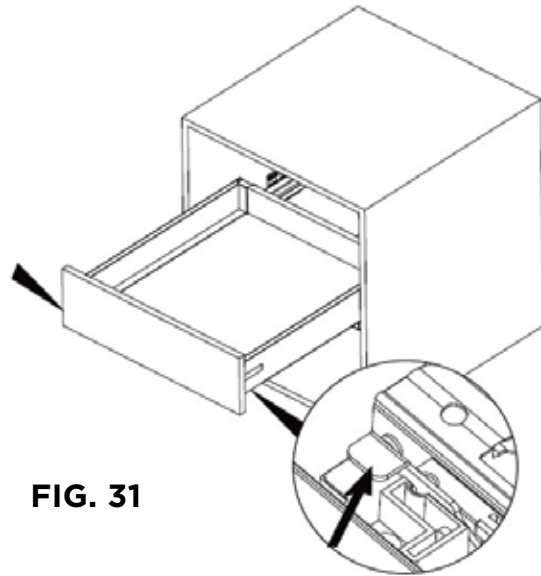
3. Rotate the unlock screw anti-clockwise to unlock the drawer front on each side. The unlock screw is on the front outer side of each drawer side, triple screw opening, refer FIG 30. Note unlock both sides.
4. The drawer front will come off.
5. To attach the drawer front again, refer page 12, FIG 19 and FIG 20.



## REMOVING THE DRAWER

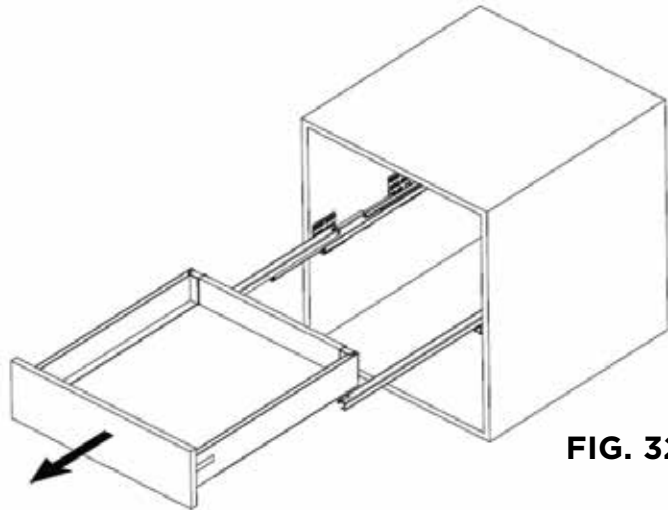
To remove the drawer from the assembled cabinet;

1. Locate the 2 tabs right at the front on each side.



**FIG. 31**

2. Slide the complete drawer out and away from the drawer runners.

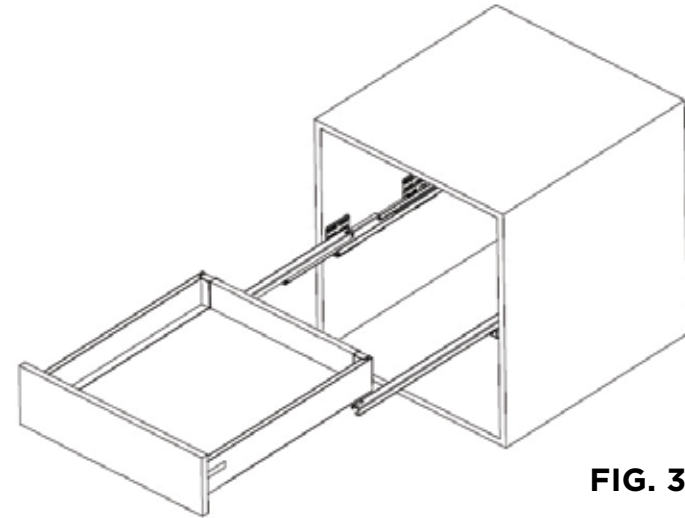


**FIG. 32**

## FITTING THE DRAWER

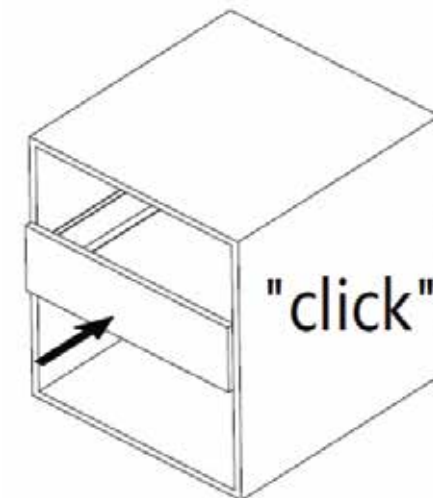
To fit the drawer from the assembled cabinet;

1. Slide out the drawer runner from each cabinet side and position the complete drawer onto the two runners.



**FIG. 33**

2. With the drawer runners positioned gently push the drawer into the cabinet, the runners will "click" into place.



**FIG. 34**

## BENCH TOP PLACEMENT

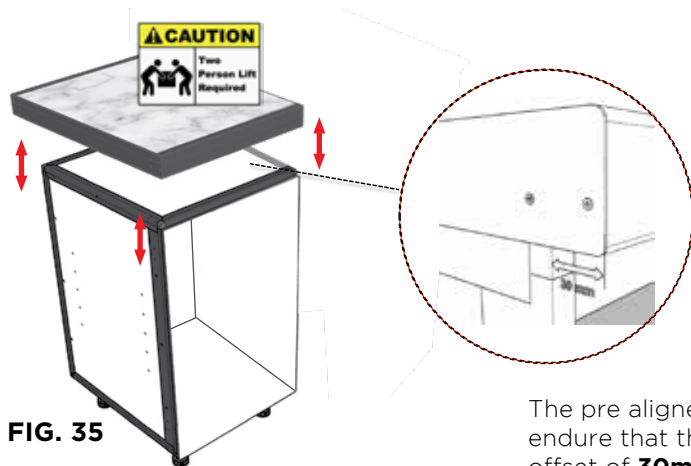
- The sintered stone is factory assembled into an aluminium frame to create an easy to fit and clean bench top.

- DANGER!**
- SINTERED STONE BENCH TOP CONTAINS CRYSTALLINE SILICA (9-10%)**
  - PRODUCT IS SUPPLIED READY TO USE. DO NOT MODIFY (EG. CUT, DRILL, SAND)**
  - IF SINTERED STONE BENCH TOP IS BROKEN RETURN TO SUPPLIER**
  - DO NOT BREATHE DUST**
  - MAY BE HARMFUL IF DUST IS INHALED**
  - SEE SAFETY DATA SHEET (INCLUDED)**



**Please note:** The bench top is deeper than the cabinet to allow for services.

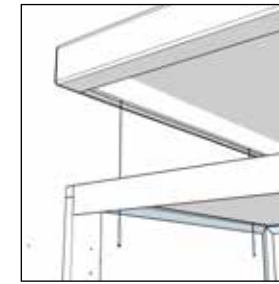
- IMPORTANT:** Assemble and level your kitchen modules, fit your End Panels and then align your tops before fixing.
- ESSENTIAL TIP:** Ensure the module and bench top are positioned on a stable flat surface to ensure alignment.
- CAUTION:** The bench top is very heavy, and a 2-person lift is required.



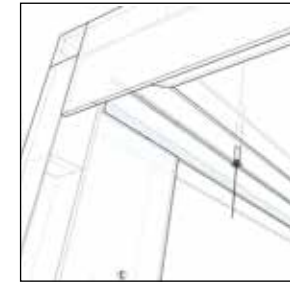
**FIG. 35**

To easily access the pre aligned screw holes remove each of the drawers by following the steps on page 16 (FIG 31 and FIG 32).

The pre aligned screw holes will ensure that the stone top has an offset of **30mm** from the cabinet.



Use the pre drilled holes to align the bench top.



Hold bench top down and tighten screws.



**FIG. 36**

Once the top is fitted and the module is level re-install each of the drawers by following the steps on page 17 (FIG 33 and FIG 34).

If the drawer fronts need to be aligned left/right/up/down refer to pages 14 & 15 (FIG 26 through FIG 29).

- Please note:** Once the module and kitchen is complete and in position, remove the bench top protective plastic sheet and dispose of in the bin, do not recycle this sheet.

For any queries or assistance call:

Customer Service  
Australia Only

1300 174 876  
[service.group@sitro.com.au](mailto:service.group@sitro.com.au)

Hours of operation:  
Monday to Friday 8am - 5pm

Do not return to place of purchase  
Keep your purchase receipt, this will be required  
to make any claims under the warranty.

Sitro Group Australia Pty Ltd  
33-35 Lionel Road, Mt Waverley,  
Victoria, 3149, Australia